

## Imperial Turbo Flow Electric Convection Ovens



Model ICVDE-2 Electric Double Deck, Bakery Depth



Model ICVE-1 Electric Single Deck, Standard Depth

### Single Deck Models

- ICVE-1 Standard Depth
- ICVDE-1 Bakery Depth

### Double Deck Models

- ICVE-2 Standard Depth
- ICVDE-2 Bakery Depth

### Imperial Turbo Flow Electric Convection Ovens

- Stainless steel exterior: doors, front, sides, legs and top.
- 11KW/240 Volt oven for both Standard depth (ICVE) and Bakery depth (ICVDE) provides high production cooking and fast recovery.
- Rugged 1/2 h.p. – two speed motor for high volume or delicate baking.
- Manual controls and programmable control option available on all models.
- Large window and two interior lights for easy viewing of products being cooked.
- Single handle simultaneously opens both doors.
- Heavy duty 60/40 stainless steel doors.
- Double bearings on the top and bottom of each door. Four bearings per door extend the life of the door mechanism and eliminates side-to-side shaft movement to improve door pressure locking.
- Door chassis is designed to endure constant opening and closing. Handle is secured to a 10 gauge stainless steel door chassis, not to the door cover. Chassis transfers the force of the doors constant opening and closing to the rugged door shaft. System is located on the top and bottom of both doors.
- Model ICVE-1 includes stainless steel legs as standard. Stainless steel shelf and adjustable rack supports are optional.
- One year parts and labor warranty.
- CGA Design Certified and NSF and CE listed.



Imperial's Turbo-Flow System provides even cooking throughout the entire oven - Creates an air flow pattern that simultaneously heats the inner and outer surfaces of the oven cavity

# Imperial Turbo Flow Electric Convection Ovens

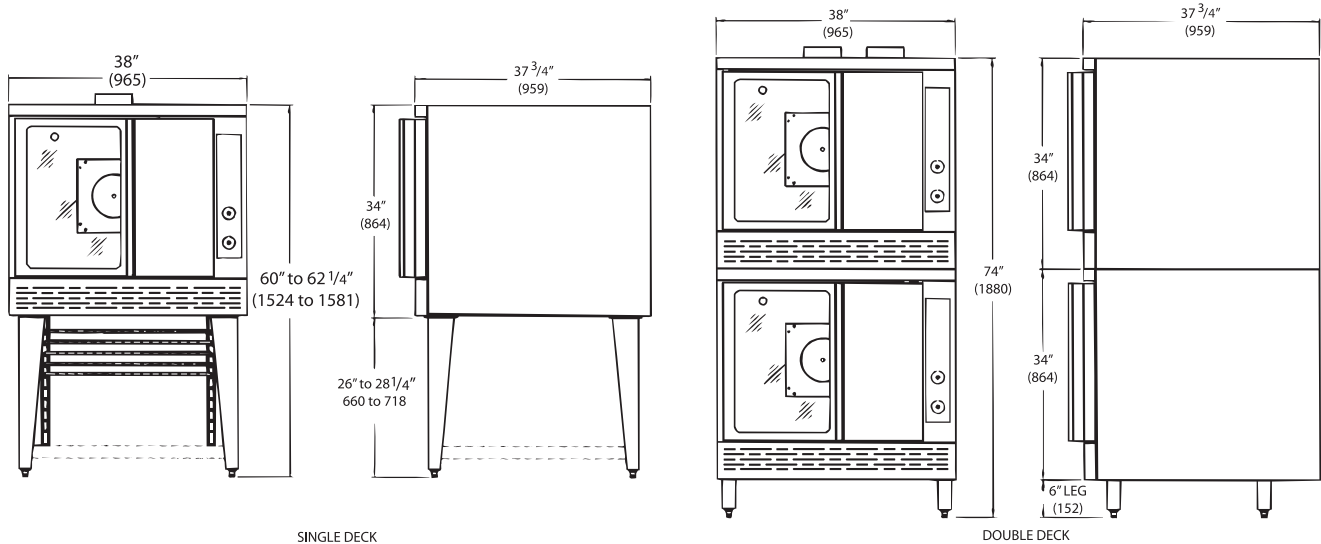

Model #	Description	Dimensions (W x D x H)	KW	Weight
ICVE-1	Single deck electric convection oven	970 x 1020 x 1525	11	236
ICVE-2	Single deck electric convection oven	970 x 1025 x 1880	22	455
ICVDE-1	Bakery depth electric convection oven	970 x 1525 x 1525	11	277
ICVDE-2	Bakery depth electric convection oven	970 x 1525 x 1880	22	536

NOTE: DIMENSIONS OF THE BACK GUARD HEIGHT HAVE BEEN MODIFIED TO AUSTRALIAN PREFERENCE, REFER TO DIMENSIONS ABOVE FOR HEIGHT, NOT ILLUSTRATION

## Standard Exterior Specifications

Front, sides, doors, legs and top shall be stainless steel with welded and finished stainless steel seams. Rigid stainless steel legs shall have an easy-to-assemble mounting plate.

Oven shall have 1/2 HP, 1725 RPM blower motor (240 volt - 50 HZ - 1Ph) 5 amp draw. Unit shall be provided with (1829mm) power cord (no plug). Unit shall include five heavy duty chrome plated racks supported by 12 position chrome plated guides. Unit shall have a three-position switch for cooking or cool down; burner "on" indicator light; and one hour manual timer or optional programmable timer.

Thermostat shall be adjustable from 150°F to 500 °F. (66 °C to 260°C).

ICVE interior cavity dimensions shall be 29" w x 24" d x 24" h (737 x 610 x 610). ICVDE interior cavity dimensions shall be 29" w x 28" d x 24" h (737 x 711 x 610).

## Electrical Requirements

240 volt, 1ph, 50 Hz, 45 amps max. (per oven)

## Minimum Clearance

For use only on non-combustible floors with legs or casters; or 2 1/4" (57) overhang is required when curb mounted. 0" clearance from non-combustible sides and rear wall. Provide 6" (152) minimum clearance from combustible side walls and 0" from combustible wall at rear.

## Certifications and Listings

CGA Design Certified and NSF and CE listed.



## Options

- Stainless steel stand with bottom shelf and adjustable rack supports
- Stainless steel enclosure back
- Heavy duty 6" (152) swivel casters
- Stacking kit with 6" (152) stainless steel legs
- Cook and Hold computer control
- 208/240 motor or transformer



Restaurant & Bar Solutions Pty Ltd  
4 Robert Street Collingwood, Vic 3066  
P: 03 9419 3333

E: sales@randbsolutions.com.au  
W: www.randbsolutions.com.au