

Gas Pasta Cooker



Model IPC-14
shown with optional casters
and stainless steel cover

Vessel is 16 gauge 317 alloy
stainless steel to withstand stronger
concentrations of salt in the water

Pasta Cooker Features

- Stainless steel front, back, vessel and sides.
- Every structural component and fastener is stainless steel for a long service life.
- 6" (152) heavy duty legs, with adjustable feet.
- One year parts and labor warranty.
- AGA and CGA design certified, NSF and CE listed.



Model Number

- IPC-14
- IPC-18

Gas Pasta Cooker

- Cooking station for pasta production.
- Exclusive water wash system removes the starch evenly across the entire surface of the water and reduces foaming.
- 110.8 (NG) & 110.8 (LPG) mj/hour burner system delivers even heat through a large oval heat exchanger tube.
- A unique baffle design efficiently transfers heat into the water throughout the entire vessel.
- The tube design and water wash systems create a natural convection action to recirculate fresh hot water into the vessel.
- Available with a manual timer or computer controls with multiple time feature for different product drop times.
- Water replacement can be adjusted from 1 gallon (3.8 L) per hour to 3 gallons (11 L) per minute depending on the specific need.
- Drain is 1 1/4" (32) diameter for quick, easy draining.
- Vessel is 16 gauge 317 alloy stainless steel. This "higher-than-marine-grade" withstands stronger concentrations of salt in the water for faster pasta preparation without boiling the water to compromise the flavor.

Optional Accessories

- Pasta Rinse-and-Hold station is stainless steel and equipped with a drain and overflow feature.
- Stainless steel cover.
- Chrome plated cooking rack to hold a variety of basket sizes.
- Automatic basket lifts, single or dual.
- Swing arm hot and cold faucet.
- Basket racks in multiple sizes.

All measurements in () are metric equivalents.

Imperial Gas Pasta Cooker

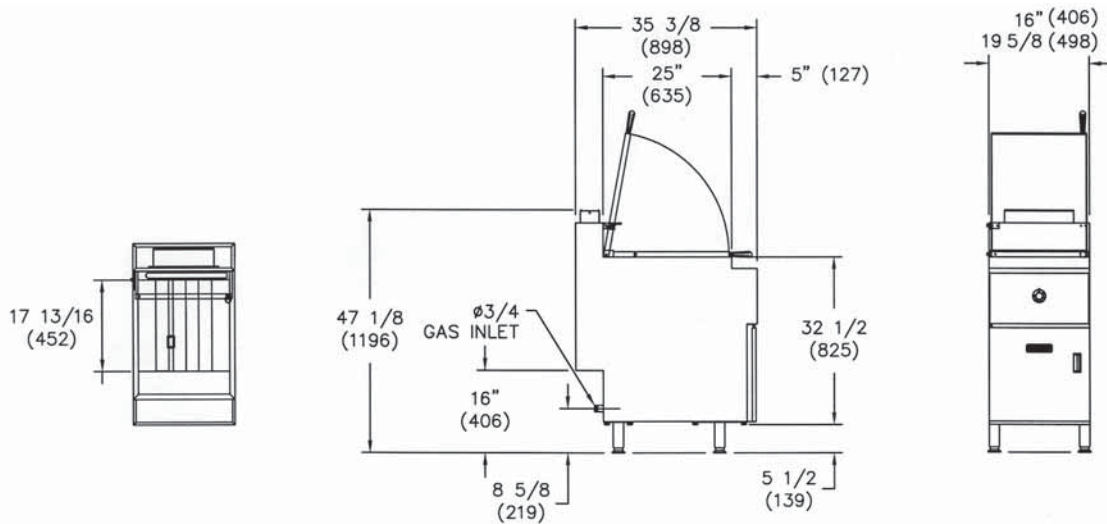

Model #	Description	Dimensions (W x D x H)	NAT	LPG	Weight
IPC-14	45 litre pasta cooker	406 x 895 x 820-970	110.8	110.8	122
IPC-18	61 litre pasta cooker	498 x 895 x 820-970	148.0	148.0	145

NOTE: DIMENSIONS OF THE BACK GUARD HEIGHT HAVE BEEN MODIFIED TO AUSTRALIAN PREFERENCE, REFER TO DIMENSIONS ABOVE FOR HEIGHT, NOT ILLUSTRATION

Standard Exterior Finish Specifications

Front, door, sides, stub back, cover and basket hanger shall be constructed of stainless steel with welded and finished stainless steel seams. Legs shall be stainless steel and adjustable.

Vessel Specifications

Vessel shall be all welded, heavy 317 gauge stainless steel. Model IPC-14 shall have a 12 gal. (45 L.) capacity and 17^{13/16}" (452) cooking area depth. Model IPC-18 shall have a 16 gal. (61 L.) capacity and a 17^{13/16}" (452) cooking area depth. Oval heat transfer tube shall be constructed of 14 gauge stainless steel. These heat transfer tubes shall be fully immersed for maximum efficiency. Energy output shall be 36.9 (NG) & 36.9 (LPG) mj/hour per burner. Heat retainer baffles located inside of tubes shall be easily removed.

A starch removal water wash system shall remove starch across the entire surface of the water while reducing foam. Water replacement shall be adjustable from 1 gal. (3.8 L) per hour to 3 gal. (11 L) per minute. Drain shall have a 1^{1/4}" (32) diameter for quick, easy draining.

Clearance

For use only on non-combustible floors. Legs or casters are required for non-combustible floors; or 2" (51) overhang is required when curb mounted. Provide 0" clearance from non-combustible surfaces and 6" (152) from combustible surfaces.

Gas

Manifold pressure is 4.0" W.C. for natural gas or 11.0" for propane gas. Manifold size 3/4" NPT. 3/4" pressure regulator built into equipment. Specify type of gas and elevation if over 2000 ft (610 m).

Optional Accessories

- Pasta Rinse-and-Hold station with stainless steel vessel, sides, front, basket hanger and stub back.
- Stainless steel cover.
- Chrome plated swing arm hot/cold faucet.
- Automatic basket lifts - single and dual.
- Pasta basket rack.
- Pasta baskets available:
 - Large bulk basket 13" x 16^{1/4}" x 10" (330 x 413 x 254)
 - Small bulk basket 13" x 13" x 8^{1/2}" (330 x 330 x 216)
 - Round baskets 4^{7/8}" x 7" (124 x 178)
- Swivel casters (front two casters are locking).



Restaurant & Bar Solutions Pty Ltd
 4 Robert Street Collingwood, Vic 3066
 P: 03 9419 3333

E: sales@randbsolutions.com.au
 W: www.randbsolutions.com.au