

Radiant Char-broilers



Model IRB-36

Broiler Features

- Stainless steel front, sides, and landing ledge.
- Welded stainless steel seams.
- Large 5" (127) stainless steel landing ledge.
- 4" (102) heavy duty stainless steel legs with adjustable feet.
- One year parts and labor warranty.
- AGA and CGA design certified, NSF and CE listed.



Model Numbers

- | | |
|---------------------------------|---------------------------------|
| <input type="checkbox"/> IRB-24 | <input type="checkbox"/> IRB-48 |
| <input type="checkbox"/> IRB-30 | <input type="checkbox"/> IRB-60 |
| <input type="checkbox"/> IRB-36 | <input type="checkbox"/> IRB-72 |

Radiant Char-broiler Features

- Individually controlled 16.0 (NG) & 18.5 (LPG) mj/hour stainless steel burners located every 6" (152).
- Removable reinforced cast iron radiants prevent clogging of burners and provide even broiling.
- Heavy duty cast iron top grates provide attractive char-broiler markings.
- 3" x 22" (76 x 559) sections remove easily and safely for cleaning.
- Slanted cooking surface provides a range of cooking temperatures.
- Each top grate blade has a cast-in grease trough that allows excess fat to flow to the front grease gutter minimizing flare-up.
- Full width grease gutter and large capacity removable drip pan.
- Insulated throughout cooktop to conserve energy.
- No tools are needed to remove grates, radiant covers and stainless steel burners for cleaning.
- Constructed for durability with heavy gauge angle iron chassis.
- Available in 24", 30", 36", 48", 60" and 72" (610, 762, 914, 1219, 1524 and 1829) width models.

All measurements in () are metric equivalents.

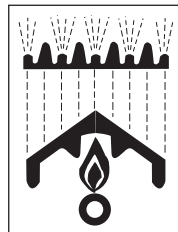

Radiant broiler system

Imperial Radiant Char-broilers

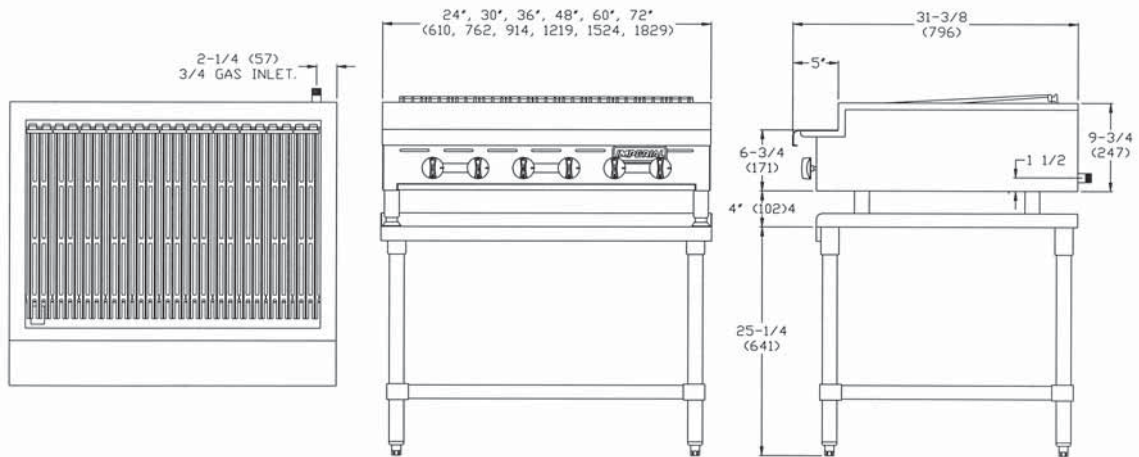

Model #	Description	Dimensions (W x D x H)	NAT	LPG	Weight
IRB-24	610mm radiant char grill	610 x 810 x 255-355	64.0	74.0	118
IRB-30	762mm radiant char grill	762 x 810 x 255-355	80.0	92.5	141
IRB-36	915mm radiant char grill	915 x 810 x 255-355	96.0	111.0	159
IRB-48	1220mm radiant char grill	1220 x 810 x 255-355	128.0	148.0	202
IRB-60	1525mm radiant char grill	1525 x 810 x 255-355	160.0	185.0	261
IRB-72	1830mm radiant char grill	1830 x 810 x 255-355	192.0	222.0	319

NOTE: DIMENSIONS OF THE BACK GUARD HEIGHT HAVE BEEN MODIFIED TO AUSTRALIAN PREFERENCE, REFER TO DIMENSIONS ABOVE FOR HEIGHT, NOT ILLUSTRATION

Standard Exterior Specifications

Front and sides shall be stainless steel. Stainless steel seams shall be welded and finished. Chassis shall be angle iron for added durability. Control knobs shall be durable cast metal, polished chrome finish. Legs shall be stainless steel 4" (102) legs with adjustable feet.

Char-broiler Specifications

Burners shall be 16.8 (NG) & 16.4 (LPG) mj/hour, Stainless steel and shall be located every 6" (152). Burners shall be removable, reinforced cast iron to prevent clogging and provide uniform distribution of heat.

Burners grates shall be heavy duty reversible cast iron. Top grates shall be constructed in 3" x 22" (76 x 559) sections. They shall be pitched forward with a cast-in grease trough in each blade for fat run off.

Grease gutter shall be full width and removable with a large capacity drip pan.

Broiler body shall be fully insulated broiler body with replaceable inner liner. No tools shall be required to remove top grates, radiant covers or stainless steel burners.

Gas: Manifold pressure is 5.0" W.C. for natural gas or 10.0" for propane gas. Manifold size 3/4" NPT. 3/4" pressure regulator supplied with equipment to be installed at time of connection. Specify type of gas and elevation if over 2000 ft. (610 m).

Clearance: For use only on non-combustible surfaces. Legs or stands are required for non-combustible floors. Provide 0" clearance from non-combustible surfaces and 8" (203) from combustible surfaces.

Optional Items:

- Stainless steel stand, 6" (152) casters (front two are locking)
- Gas shut off valve 3/4" (19)
- Quick disconnect and flexible gas hose
- Fish top grates



Restaurant & Bar Solutions Pty Ltd
4 Robert Street Collingwood, Vic 3066
P: 03 9419 3333

E: sales@randbsolutions.com.au
W: www.randbsolutions.com.au